



Foundation Blocks

Celcon Foundation Blocks are commonly produced in a range of thicknesses for use below ground level. Offering beneficial thermal performance, they are suitable for the support of cavity or solid walls, framed construction or suspended floors, including beam and block floors. They are resistant to damage caused by water penetration.



With exceptional resistance to freeze/thaw conditions and sulfate attack when they occur below ground level: BBA certificate 01/3816 confirms that all Celcon Foundation Blocks are suitable for use in soil conditions from DS1 to DS4.

Celcon Foundation Blocks can be laid below ground level without mortar perpends. Simply lay them with mortared horizontal bed joints and then butt them together to prevent the passage of vermin.

Solar Grade can also be used below ground.

All Celcon Foundation Blocks may also be used above ground, with appropriate finishes, for solid wall construction.



Applications

- Foundations
- Solid wall construction

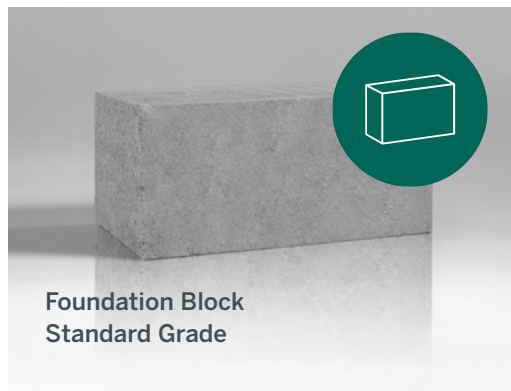



Foundation Blocks

Face size	Standard Grade 440mm x 215mm			High Strength Grade 440mm x 215mm		
Block Thickness (mm)	275	300	355	275	300	355
Block Weight (kg) [†]	20	22	26	27	29	35

Face size	Standard Grade 325mm x 215mm	High Strength Grade 325mm x 215mm
Block Thickness (mm)	300	300
Block Weight (kg) [†]	16	16

Face size	Standard Grade	High Strength Grade
Compressive Strength	3.6N/mm ²	7.3N/mm ²
Thermal Conductivity	0.24 W/mK*	0.29 W/mK*
Density	600 kg/m ³	730 kg/m ³

[†] Block weights at typical moisture content when laid. (Some manufacturers may quote weights which have not allowed for this.)

All shaded areas indicate that the product is a stock item. Other sizes can be made to order subject to minimum quantities.

24 Bold green figures indicate that the product is above single person repetitive manual handling limits.

* Please note that the thermal conductivity quoted for use below ground is different to that when used above DPC, because they may have higher moisture content.

Pack Information

Blocks/m ² laid 13.27 (10mm joints)	325 x 215mm
Coverage per pack (m ²) – 10mm joint	3
Number of blocks per pack	40
Pack width (mm) = W	1075
Pack weight – Standard Grade (kg)	646
Pack weight – High Strength/ Super Strength (kg)*	742

Celcon Foundation Blocks (325mm x 215mm)

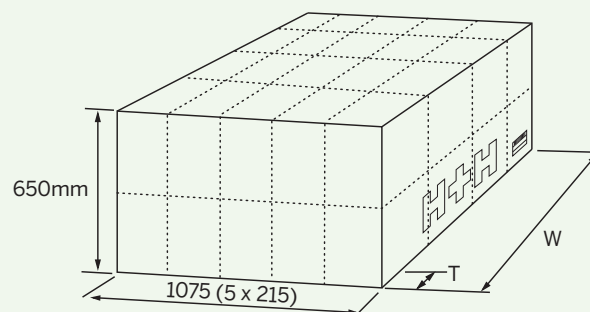

* Pack weight excludes pallet.

For further information and to check our most up-to-date product range, or to find your nearest stocking merchant, please visit our website www.hhcelcon.co.uk or contact the following departments:

Sales

For sales enquiries or to find your local stockist please contact
Tel: 01732 886444
Fax: 01732 887013

Technical

For technical enquiries please contact
Tel: 01732 880580
Fax: 01732 887013

H+H UK will always endeavour to reflect our product range and technical information as accurately as possible. We may however, need to update both from time to time during the life of this brochure. Please check with either our Sales or Technical departments to obtain the latest information prior to specification and purchase.